



All of our in-house printed paper is 100% recycled and recyclable

STOANE LIGHTING

EQUIPMENT DESIGN + MANUFACTURE



ZTA 50 Pendant Star (Very Narrow Beam)

Installation and Maintenance Instructions

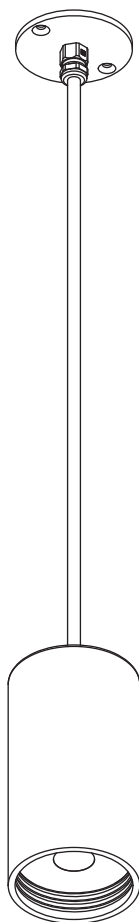

IMPORTANT: All wiring connections must be made before switching on mains power.



MSL Star 2.9V_F 2W @ 700mA



This product should not be disposed of in your general waste



Please retain these instructions for future reference



Class III - Extra Low Voltage



IP20 Indoor Use Only



European Conformity

Stoane Lighting Ltd
20 Dryden Road Bilston Glen Ind Est.
Loanhead Midlothian EH20 9LZ UK

T: +44 (0) 131 440 1313
F: +44 (0) 131 440 0049
sales@mikestoanelighting.com

www.stoanelighting.com
VAT No GB682885284
Limited Company 188910

Electrical Supply

Installation must be carried out by a qualified electrician in accordance with BS 7671:2008 Wiring Regulations. 230/240V AC 50/60Hz mains supply to a suitable SELV LED Driver.

Site conditions: LED equipment is more susceptible to static damage and over voltage than previous technology. Before handling or connecting to the mains supply ensure that all Stoane Lighting (SL) products are protected from static discharge and that the mains supply is to regulation. (230V +10 -6%)

Mains cables must be double insulated, strain relieved and separated from E.L.V output cables.

This fitting can be supplied with unit requires a constant current driver. See product label for recommended drive current.

Observe polarity:
Positive (+) is marked as RED.
Incorrect supply or reverse polarity can cause irreparable damage.

All connections must be made before switching on mains. If the supply is energised prior to making the connections to the fitting then the resulting surge will damage the LED.

Multiple LEDs should be wired in series, refer to driver instructions for minimum/maximum load.

The entire dimming control circuit source must be of SELV insulation class.

Maintenance:

All lighting equipment is delicate and easily damaged through misuse or inappropriate installation (mechanical or electrical). Repairs and replacements may cause delays and will be chargeable. Contact SL for support if required.

All Stoane Lighting products are covered by a five year Warranty and a 25 year Duty of Care. Products are designed to be upgraded, adapted and refreshed using our comprehensive ReNew service. For more information on our ReNew service and for full Warranty terms and conditions visit stoanelighting.com or contact us at the address shown.

The light source contained in this luminaire shall only be replaced by the manufacturer or his service agent or a similar qualified person.

Installation

Check that the mounting surface is suitable for the installation of this fitting.

A 20mm diameter hole is required for supply cable.

Step 1 Make mains connections to SELV LED driver and extra low voltage connections to the fitting.

Step 2 Adjust the drop height as required and fully tighten the gland on the mount plate to grip in place.

Step 3 Mount the fitting with two suitable fixings.

All suspended installations should be inspected by a competent person at least once a year

WARNING: Do not look at exposed LED lamps in operation. Eye injury can result.

Additional items should not be hung or suspended from this fitting. SL takes no responsibility for additional items added by others or the consequences of those items.

Cleaning:

Fully isolate the fitting and allow to cool.

Clean the fitting with a slightly damp lint free cloth from a mild solution of soap and water. The fitting must be completely dry before reconnecting power.

Incompatible or abrasive chemicals can damage the fitting, contact SL for advice if required.

STOANE LIGHTING

EQUIPMENT DESIGN + MANUFACTURE

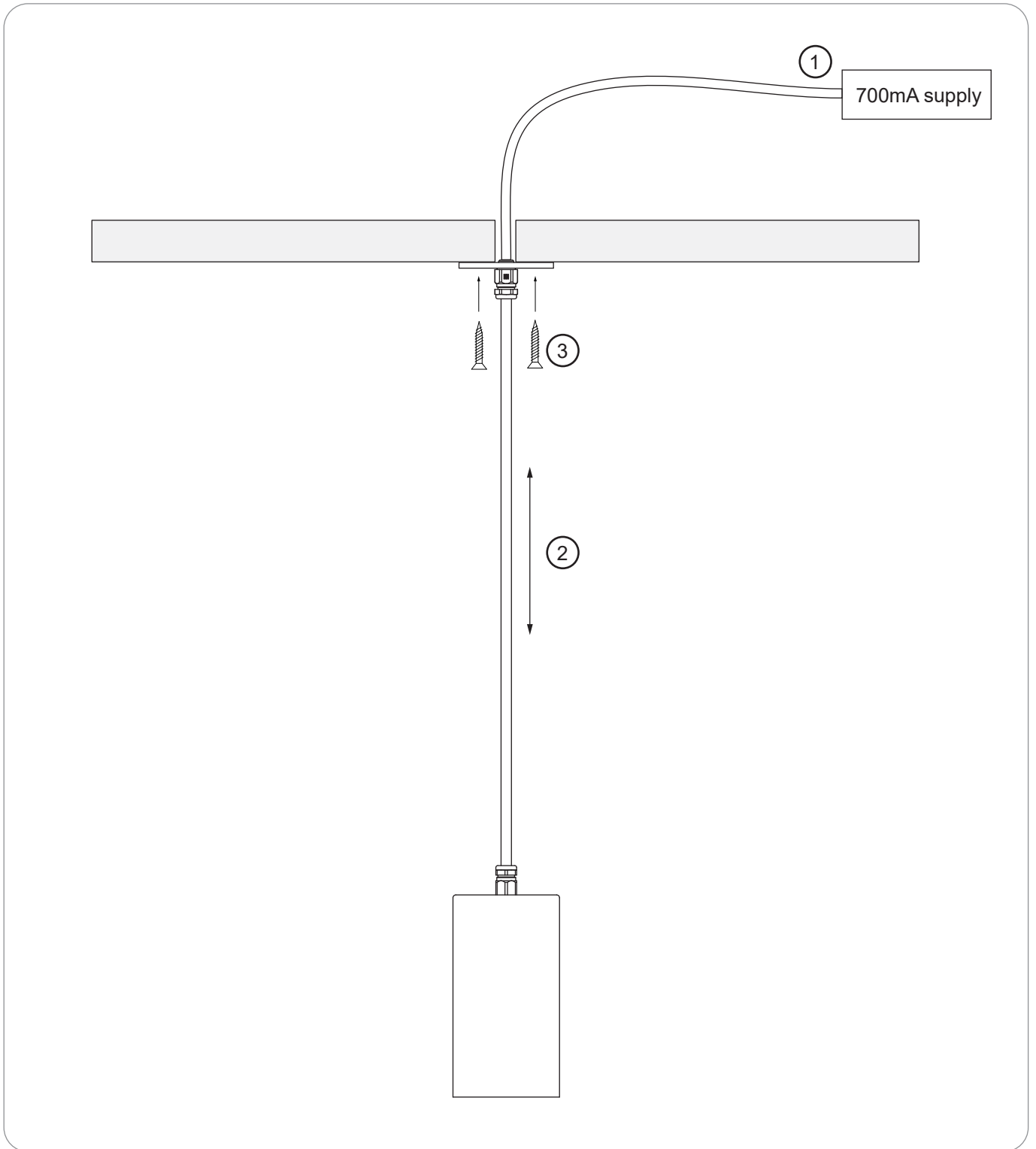

MODULE AND ACCESSORIES

The colour temperature and lumen output can be found on the product label on the fitting.

To add/remove accessories:

Isolate the fitting from the supply and allow to cool.

Step 1 To remove optic and accessories remove circlip.

Step 2 Replace optic/accessories as required and replace circlip to secure.

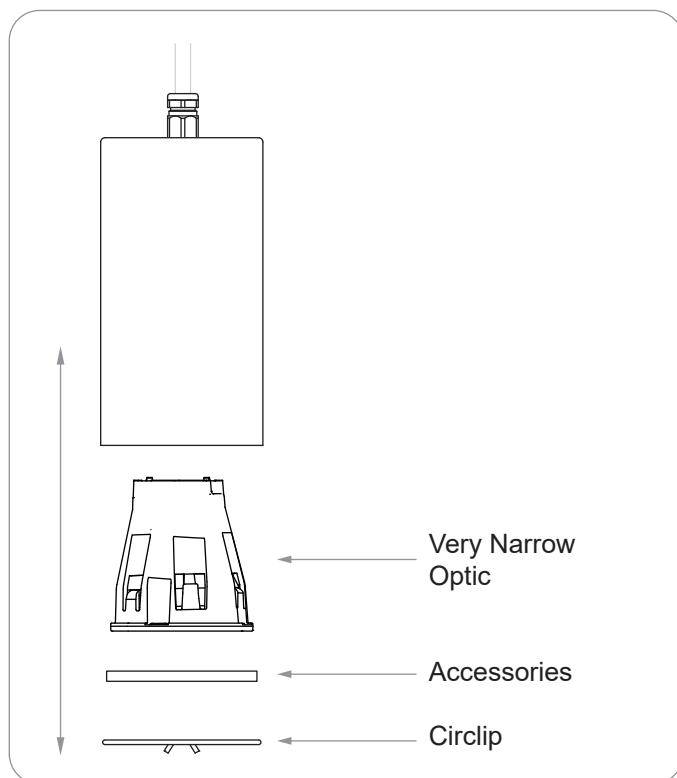

STOANE LIGHTING

EQUIPMENT DESIGN + MANUFACTURE

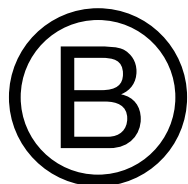
Certified**Corporation**

Stoane Lighting firmly believe that we have a responsibility as environmental custodians, we believe that lighting equipment should be built to last, to be repaired and to be reused. As a BCorp we believe that we must look to operate in a business not aiming to just be best in the world but a business best for the world. Stoane Lighting believe that the circular economy is a fundamental aspect of how we approach the challenges we face. If you read this at the end of the product life we encourage you to consider how you can ensure these products see an extended life.

All Stoane Lighting products are supplied with a 5 year warranty and a 25 year duty of care.

Stoane Lighting operate a ReNew division, which can take your existing fittings and refurbish or upgrade without the need for replacing what you already have.



Through the ReNew service, Stoane Lighting provides general repair, deep cleans and electrical safety checks on luminaires, as well as possible repainting if needed. We will replace components that are nearing end of life, such as drivers, LEDs, and optics. If the fittings are to be used in a new area, or the existing space is undergoing a change in use, ReNew can offer a different mounting method or light technical performance (such as colour tuning), if needed, alongside the addition of on-board wireless control.



Once fittings have been repaired or upgraded through ReNew, they will start a new five-year warranty period, and any unwanted parts will be recycled.

For more information the Warranty, Duty of Care or ReNew service please visit stoanelighting.com or contact us at the address shown.