



All of our in-house printed paper is 100% recycled and recyclable

STOANE LIGHTING

EQUIPMENT DESIGN + MANUFACTURE



ZTA.35 Mains Track

Installation and Maintenance Instructions

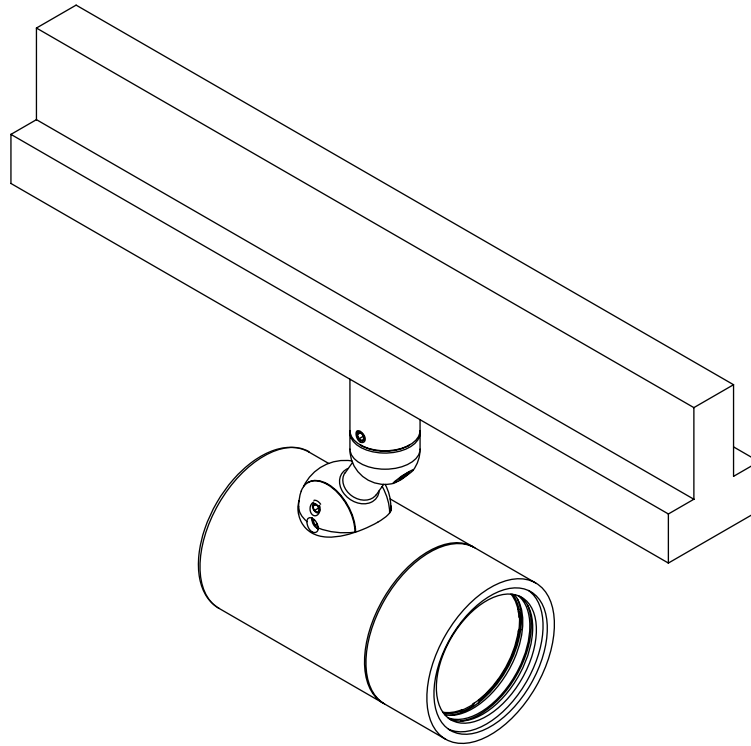

IMPORTANT: All wiring connections must be made before applying power.



Xicato XOB 6mm 3000K 95 CRI 34.1Vf 7.9W @ 250mA



Do not stare at the operating light source



This product should not be disposed of in your general waste



Please retain these instructions for future reference



Class II - Double insulated fitting

IP20 Indoor Use Only

t_a 35°C Rated maximum ambient temperature

CE European Conformity

UK CA UKCA (UK Conformity Assessed)

Stoane Lighting Ltd
20 Dryden Road Bilston Glen Ind Est.
Loanhead Midlothian EH20 9LZ UK

T: +44 (0) 131 440 1313
F: +44 (0) 131 440 0049
sales@mikestoanelighting.com

www.stoanelighting.com
VAT No GB682885284
Limited Company 188910



All of our in-house printed paper is 100% recycled and recyclable

STOANE LIGHTING

EQUIPMENT DESIGN + MANUFACTURE

Certified



Corporation

Electrical Supply

Installation must be carried out by a qualified electrician in accordance with BS 7671:2018 + A2:2022 Wiring Regulations. 230/240V AC 50/60Hz mains supply to suitable lighting track.

Site conditions: LED equipment is more susceptible to static damage and over voltage than previous technology. Before handling or connecting to the mains supply ensure that all Stoane Lighting (SL) products are protected from static discharge and that the mains supply is to regulation. (230V +10 -6%)

This fitting is supplied with a Xicato LED module. Refer to the fitting label for the module version and wattage. More information on the module can be found at www.xicato.com/support

This product contains a light source of energy efficiency class F.

Mains cables must be double insulated, strain relieved and separated from E.L.V output cables.

Observe polarity:
Incorrect supply or reverse polarity can cause irreparable damage.

All connections must be made before applying power. If the supply is energised prior to making the connections to the fitting then the resulting surge will damage the LED.

The entire dimming control circuit source must be of SELV insulation class.

SL can provide assistance on dimming compatibility or control systems by request. For advice on specific dimming systems we recommend seeking assistance from the commissioning engineer or the control systems provider in the first instance.

Maintenance:

All lighting equipment is delicate and easily damaged through misuse or inappropriate installation (mechanical or electrical). Repairs and replacements may cause delays and will be chargeable. Contact SL for support if required.

All Stoane Lighting products are covered by a five year Warranty and a 25 year Duty of Care. Products are designed to be upgraded, adapted and refreshed using our comprehensive ReNew service. For more information on our ReNew service and for full Warranty terms and conditions visit stoanelighting.com or contact us at the address shown.

When supplying digital equipment with the potential to be connected to networks, physically or wirelessly (i.e. Bluetooth, WiFi, DMX radio etc.), SL does not take responsibility for the digital security of the equipment or associated networks. It is the customer's responsibility to select a protocol suitably robust for their requirements and to ensure responsible utilisation of passwords.

The light source contained in this luminaire shall only be replaced by the manufacturer or his service agent or a similar qualified person.

Full disassembly notes are available on our website, and are accessed by entering your product serial number into the search function of our website. Serial numbers are typically located in an area that is not visible when the fitting is installed.

Cleaning:

Fully isolate the fitting and allow to cool.

Clean the fitting with a slightly damp lint free cloth from a mild solution of soap and water. The fitting must be completely dry before reconnecting power.

Incompatible or abrasive chemicals can damage the fitting, contact SL for advice if required.



All of our in-house printed paper is 100% recycled and recyclable

STOANE LIGHTING

EQUIPMENT DESIGN + MANUFACTURE



Installation

Check that the track is mounted securely and is capable of supporting the total weight of the installed fittings.

Fitting Weight : 0.5kg.

This fitting should be mounted out of arms reach to prevent unauthorized adjustment.

Track must always be mounted to a horizontal ceiling, mounting track vertically or on a wall, or at an angle will result in damage to the fittings.

Step 1 Insert the track adaptor into the track and secure via the locking tab.

Whilst holding the fitting, turn the fitting through 90° and the fitting will be locked in place.

Step 2 Rotate the circuit selector to the required circuit.

WARNING: Do not look at exposed LED lamps in operation. Eye injury can result.

Additional items should not be hung or suspended from this fitting. SL takes no responsibility for additional items added by others or the consequences of those items.

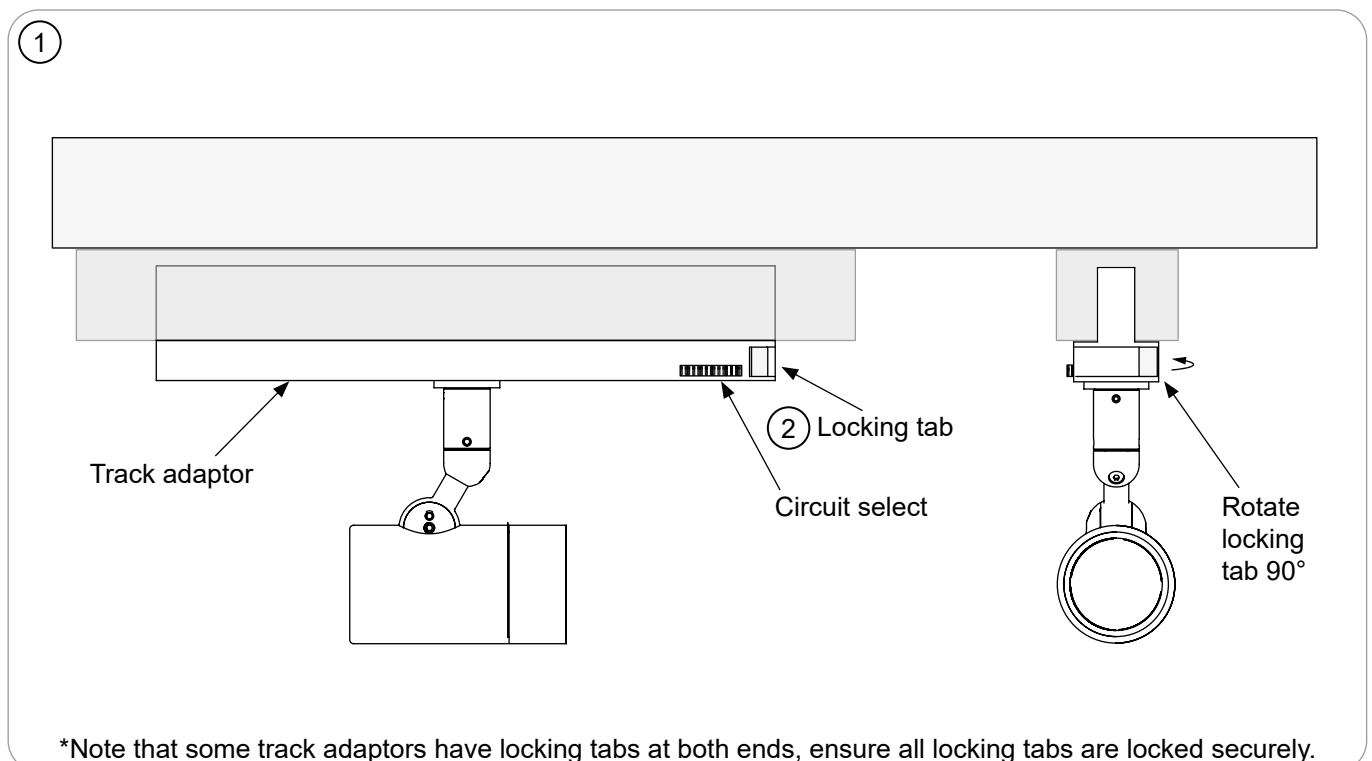



All of our in-house printed paper is 100% recycled and recyclable

STOANE LIGHTING

EQUIPMENT DESIGN + MANUFACTURE



MODULE AND ACCESSORIES

The colour temperature and lumen output can be found on the product label on the fitting.

To add/remove optic and accessories:

Isolate the fitting from the supply and allow to cool.

Step 1 Pull the lamptube to remove.

Step 2 Replace the optic and accessory as required. Rotate the optic counter clockwise to remove, rotate clockwise to secure in place.

Step 3 Push the lamptube firmly back onto the fitting.

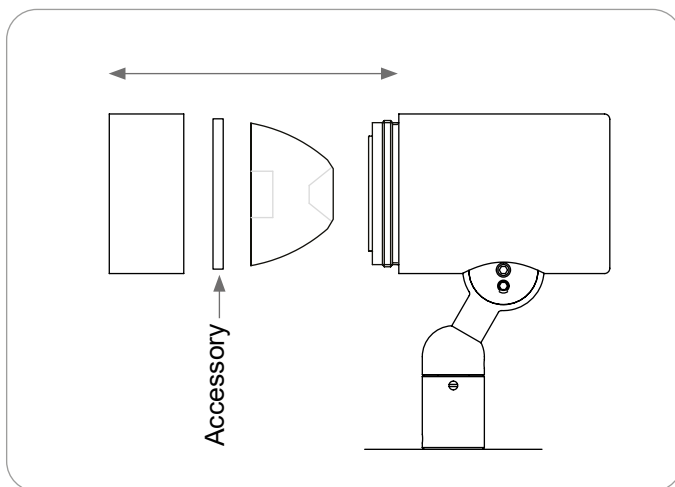

ZTA Zoom

To adjust the angle of the beam rotate the zoom lens clockwise until the desired beam is reached.

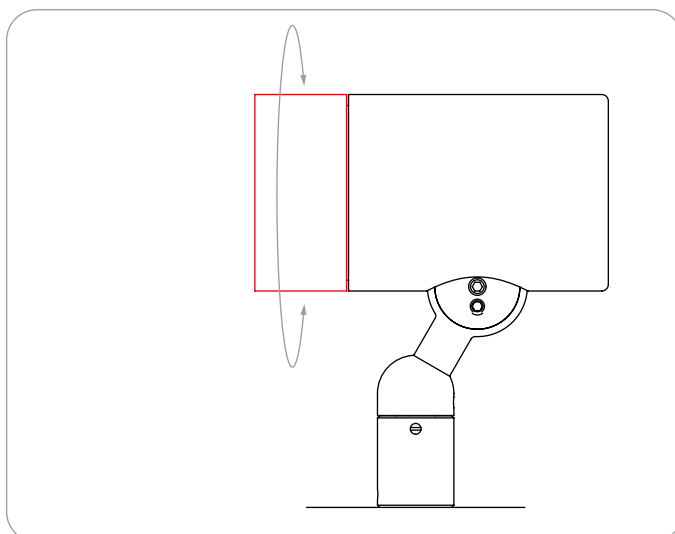

ADJUSTMENT

To adjust the tilt and pan of the fitting use the supplied 2mm Allen key to loosen off the tilt and pan lock screws.

Once the desired angle is achieved lock off the screws.

DO NOT over tighten the screws as this could damage the lock and cause it to no longer function.

Pan

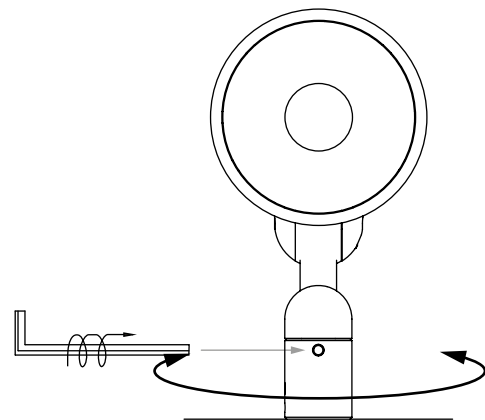

Tilt

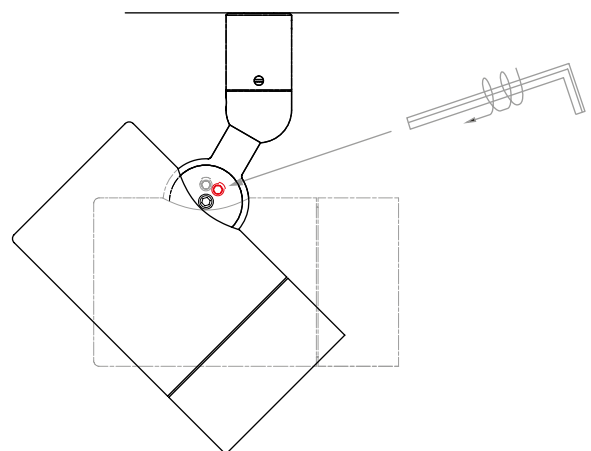



All of our in-house printed paper is 100% recycled and recyclable

STOANE LIGHTING

EQUIPMENT DESIGN + MANUFACTURE



On Board Dimming (Optional)

An optional 1-10V dimming pot version is available.

To dim the fitting rotate the dim pot to the required level.

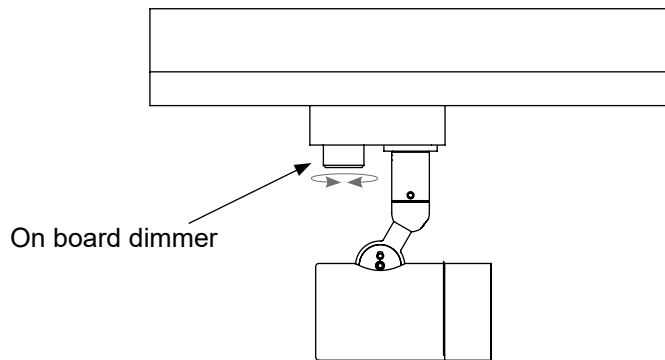



All of our in-house printed paper is 100% recycled and recyclable

STOANE LIGHTING

EQUIPMENT DESIGN + MANUFACTURE



Stoane Lighting firmly believe that we have a responsibility as environmental custodians, we believe that lighting equipment should be built to last, to be repaired and to be reused. As a BCorp we have pledged to operate a business not aiming to just be best in the world but a business best for the world. Stoane Lighting believe that the circular economy is a fundamental aspect of how we approach the challenges we face. If you read this at the end of the product life we encourage you to consider how you can ensure this product sees an extended life. If removal is unavoidable, please see the disassembly note below.

All Stoane Lighting products are supplied with a 5 year warranty and a 25 year duty of care.

Stoane Lighting operate a ReNew division, which can take your existing fittings and refurbish or upgrade without the need for replacing what you already have.



Through the ReNew service, Stoane Lighting provides general repair, deep cleans and electrical safety checks on luminaires, as well as possible repainting if needed. We will replace components that are nearing end of life, such as drivers, LEDs, and optics. If the fittings are to be used in a new area, or the existing space is undergoing a change in use, ReNew can offer a different mounting method or light technical performance (such as colour tuning), if needed, alongside the addition of on-board wireless control. ReNew as a service, depending on location, can be done on site or by returning equipment to Stoane Lighting.



Once fittings have been repaired or upgraded through ReNew, they will start a new five-year warranty period, and any unwanted parts will be recycled.



Product Disassembly and Component Recycling - While every effort has been made to ensure that our products are built to last and are ReNewable, there may come a point when, as a very last resort, the fittings need to be recycled. The Stoane Lighting website will provide information on how the fitting can easily be disassembled into its component parts for more effective recycling. Information on recycling services in your local region can also be supplied on request.

For more information on the above please visit stoanelighting.com or contact us at the address shown.