



All of our in-house printed paper is 100% recycled and recyclable

**STOANE LIGHTING**

EQUIPMENT DESIGN + MANUFACTURE



# Surf S

## Installation and Maintenance Instructions

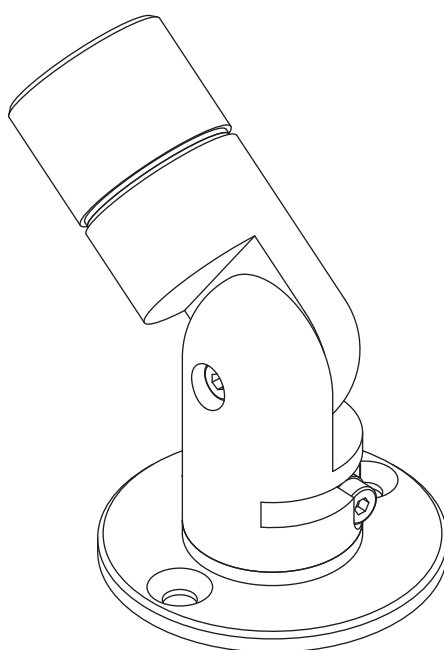

**IMPORTANT: All wiring connections must be made before switching on mains power.**



SL Type S 2.85V<sub>F</sub> 1.4W @ 500mA



Do not stare at the operating light source



This product should not be disposed of in your general waste



Please retain these instructions for future reference



Class III - Extra Low Voltage

**IP20** Indoor Use Only

$t_a$  35°C Rated maximum ambient temperature



European Conformity



UKCA (UK Conformity Assessed)

Stoane Lighting Ltd  
20 Dryden Road Bilston Glen Ind Est.  
Loanhead Midlothian EH20 9LZ UK

T: +44 (0) 131 440 1313  
F: +44 (0) 131 440 0049  
sales@mikestoanelighting.com

www.stoanelighting.com  
VAT No GB682885284  
Limited Company 188910

## Electrical Supply

Installation must be carried out by a qualified electrician in accordance with BS 7671:2018 + A2:2022 Wiring Regulations. 230/240V AC 50/60Hz mains supply to a suitable SELV LED Driver.

Site conditions: LED equipment is more susceptible to static damage and over voltage than previous technology. Before handling or connecting to the mains supply ensure that all Stoane Lighting (SL) products are protected from static discharge and that the mains supply is to regulation. (230V +10 -6%)

This product contains a light source of energy efficiency class F.

Mains cables must be double insulated, strain relieved and separated from E.L.V output cables.

**This unit requires a constant current driver. 500mA Max.**

**Observe polarity:  
Positive (+) is marked as RED.  
Incorrect supply or reverse polarity can cause irreparable damage.**

**All connections must be made before switching on mains.** If the supply is energised prior to making the connections to the fitting then the resulting surge will damage the LED.

Multiple LEDs should be wired in series, refer to driver instructions for minimum/maximum load.

The entire dimming control circuit source must be of SELV insulation class.

**WARNING: Do not look at exposed LED lamps in operation. Eye injury can result.**

Additional items should not be hung or suspended from this fitting. SL takes no responsibility for additional items added by others or the consequences of those items.

## Maintenance:

All lighting equipment is delicate and easily damaged through misuse or inappropriate installation (mechanical or electrical). Repairs and replacements may cause delays and will be chargeable. Contact SL for support if required.

All Stoane Lighting products are covered by a five year Warranty and a 25 year Duty of Care. Products are designed to be upgraded, adapted and refreshed using our comprehensive ReNew service. For more information on our ReNew service and for full Warranty terms and conditions visit [stoanelighting.com](http://stoanelighting.com) or contact us at the address shown.

When supplying digital equipment with the potential to be connected to networks, physically or wirelessly (i.e. Bluetooth, WiFi, DMX radio etc.), SL does not take responsibility for the digital security of the equipment or associated networks. It is the customer's responsibility to select a protocol suitably robust for their requirements and to ensure responsible utilisation of passwords.

The light source contained in this luminaire shall only be replaced by the manufacturer or his service agent or a similar qualified person.

If the external flexible cable or cord of this luminaire is damaged, it shall be exclusively replaced by the manufacturer or his service agent or a similar qualified person in order to avoid a hazard.

Full disassembly notes are available on our website, and are accessed by entering your product serial number into the search function of our website. Serial numbers are typically located in an area that is not visible when the fitting is installed.

## Cleaning:

Fully isolate the fitting and allow to cool.

Clean the fitting with a slightly damp lint free cloth from a mild solution of soap and water. The fitting must be completely dry before reconnecting power.

Incompatible or abrasive chemicals can damage the fitting, contact SL for advice if required.

## Installation

Check that the mounting surface is suitable for the installation of this fitting.

A 4mm diameter hole is required when routing the cables.

Step 1 Make mains connections to SELV LED driver and extra low voltage connections to the fitting.

Step 2 Secure the fitting in position using suitable fixings.

Step 3 Adjust and lock the pan and tilt position.

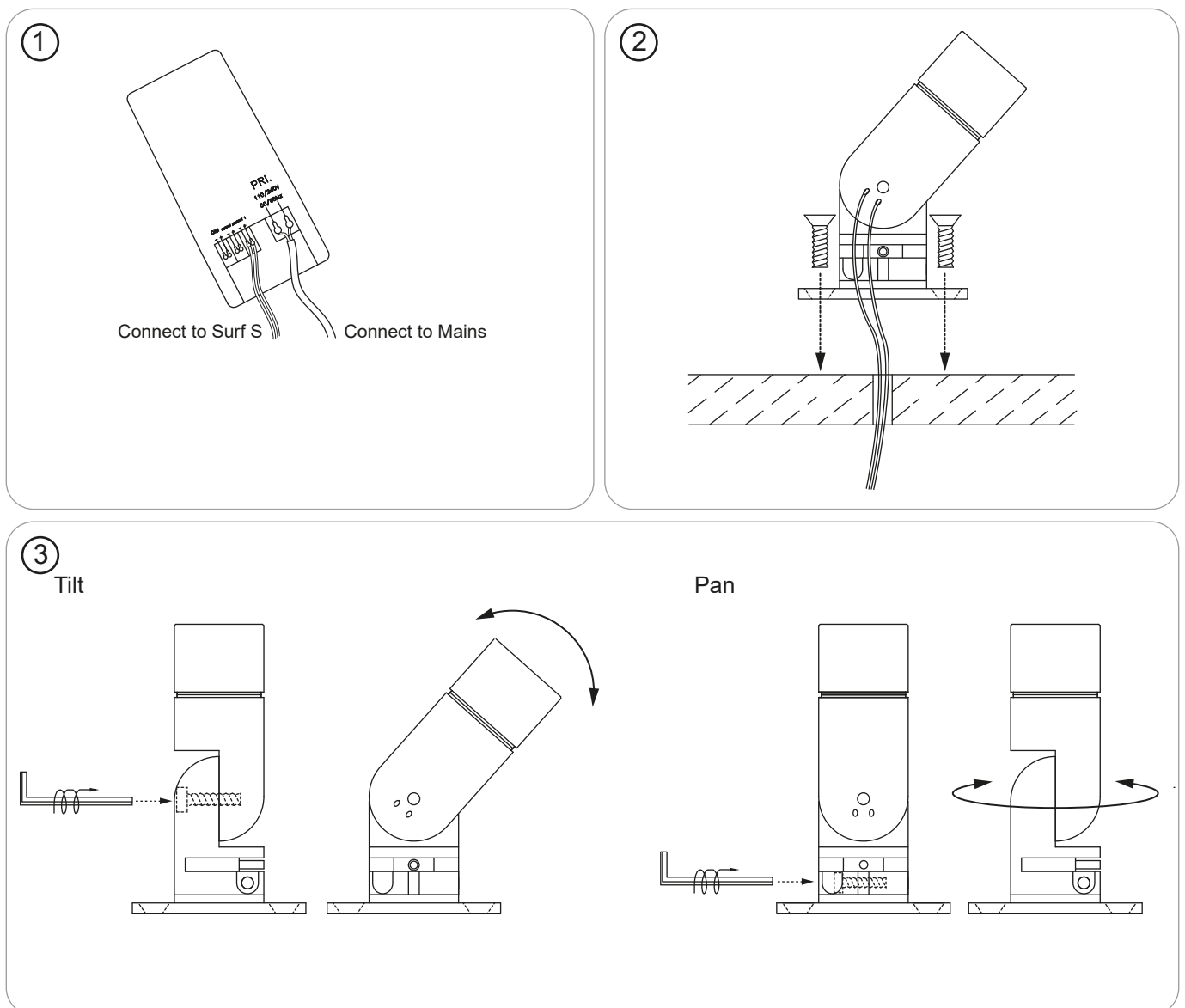

**OPTIC CHANGE**

Step 1 Remove the bezel by unscrewing.

Step 2 Remove the optic from the bezel.

Step 3 Insert new optic into the retaining tube and replace components shown into the body of the fitting.

Step 4 Screw the bezel back into the body until fully tightened.

**Warning - Failure to tighten fully with all appropriate components in place may result in premature failure of fitting.**

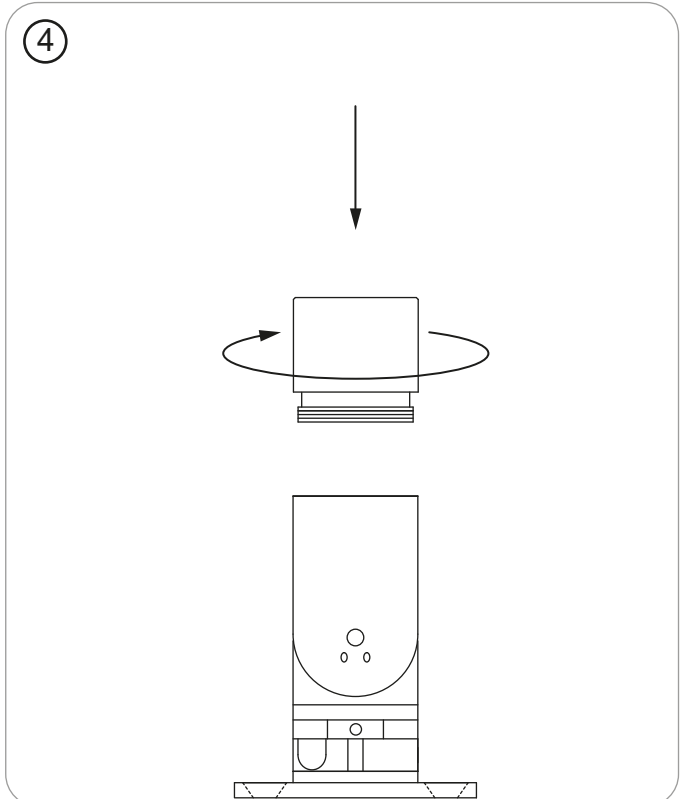
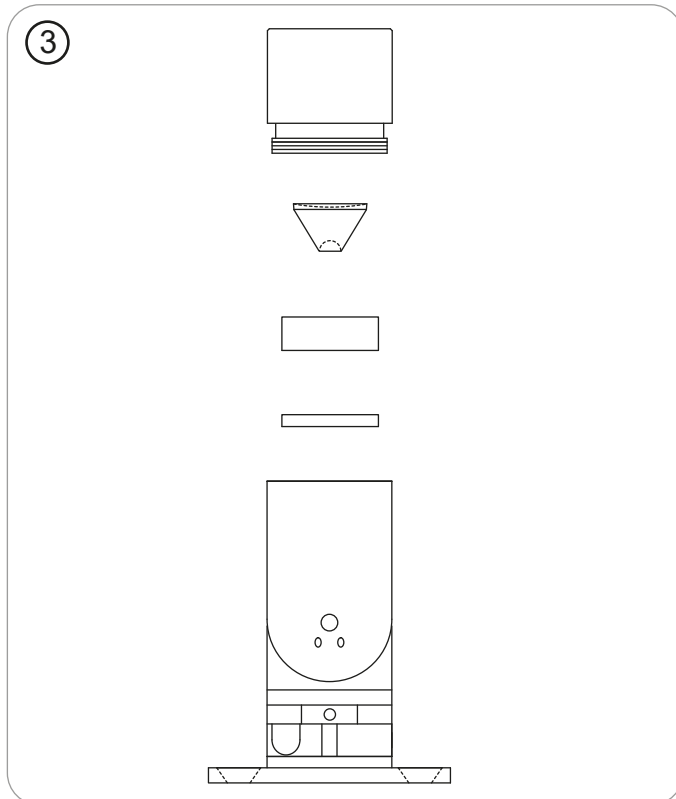
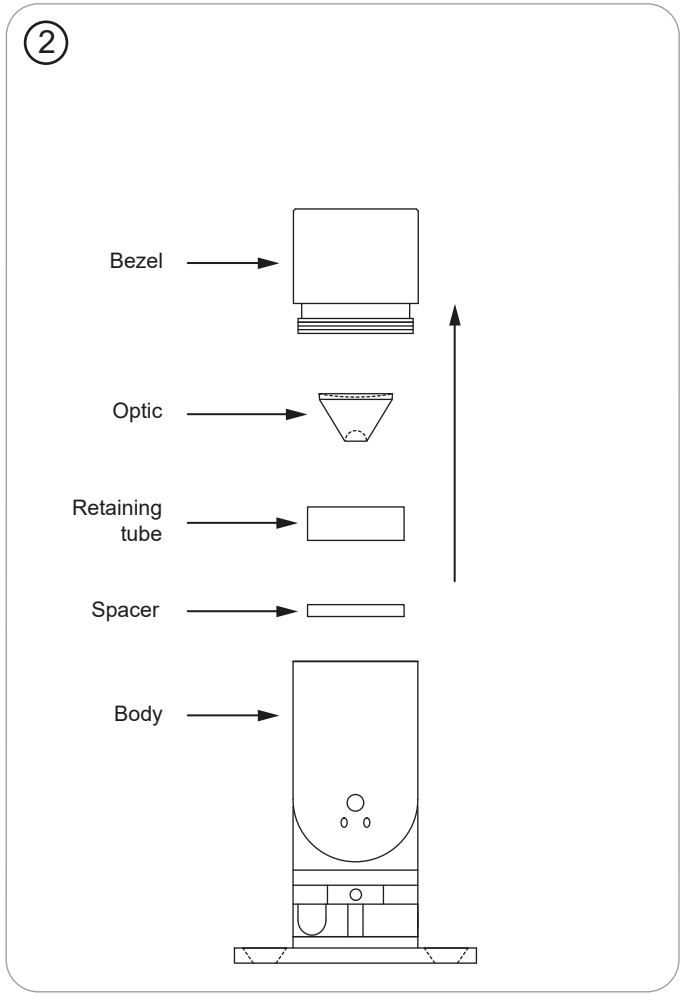
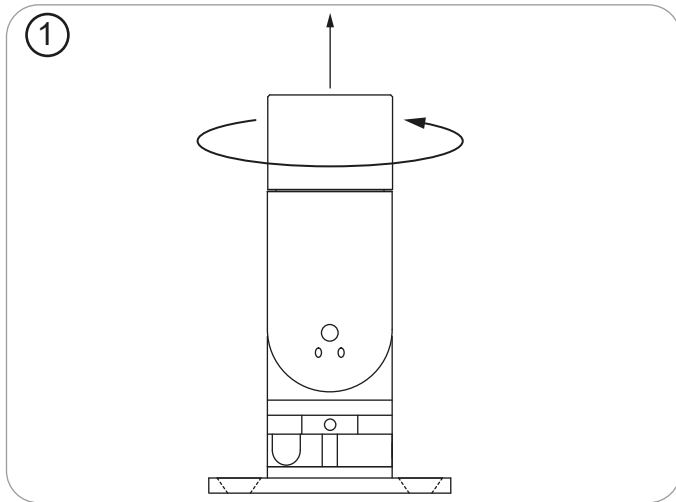

## Very Narrow Beam Accessory

### Adding the Narrow Beam Accessory

Step 1 First remove the standard Surf S bezel by unscrewing.

Step 2 Remove the bezel, optic and optic retaining clip.

Step 3 Screw the narrow beam optic holder into the body until fully tightened.

Step 4 Add or remove the diffuser as required and screw the narrow beam bezel onto the fitting.

Note that the supplied diffuser can be used to give a cleaner beam, or can be removed to give a tighter beam.

**Warning - Failure to tighten fully with all appropriate components in place may result in premature failure of fitting.**

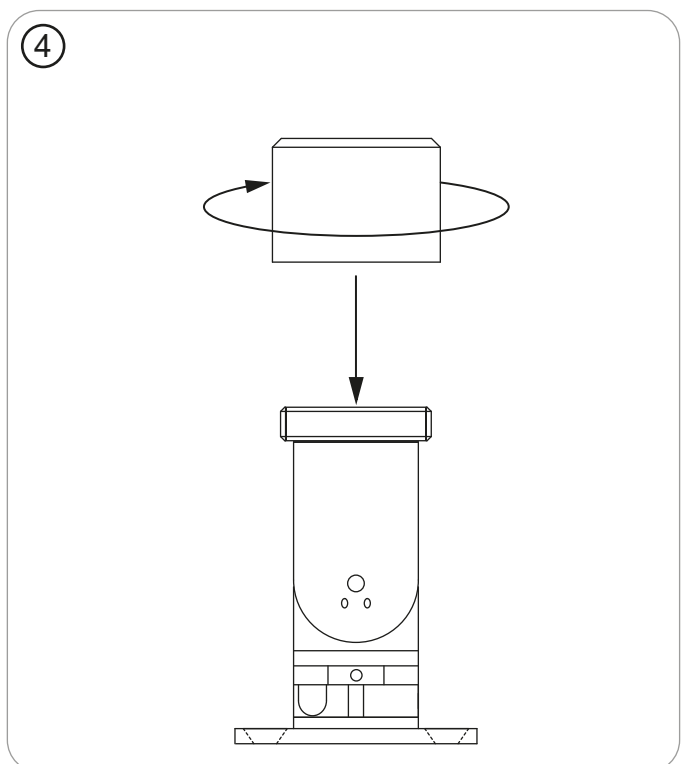
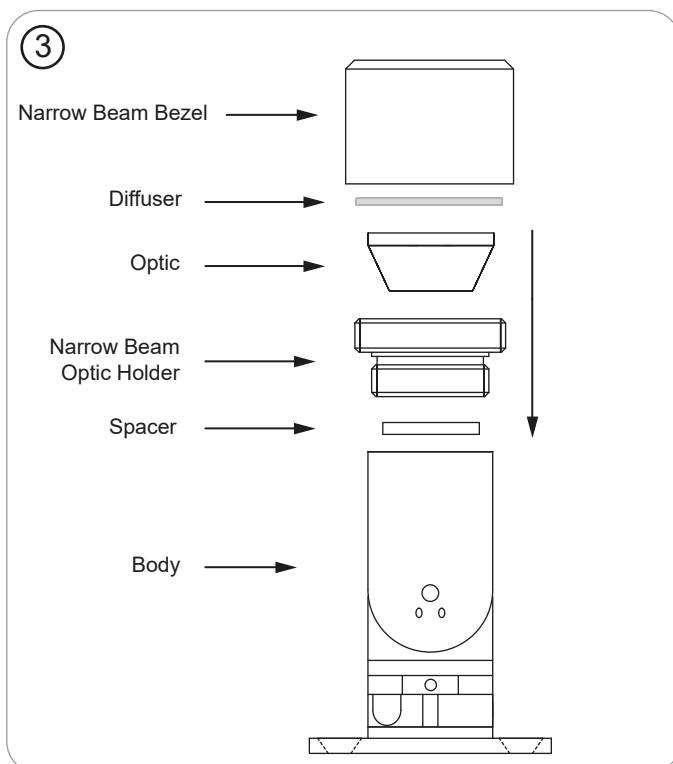
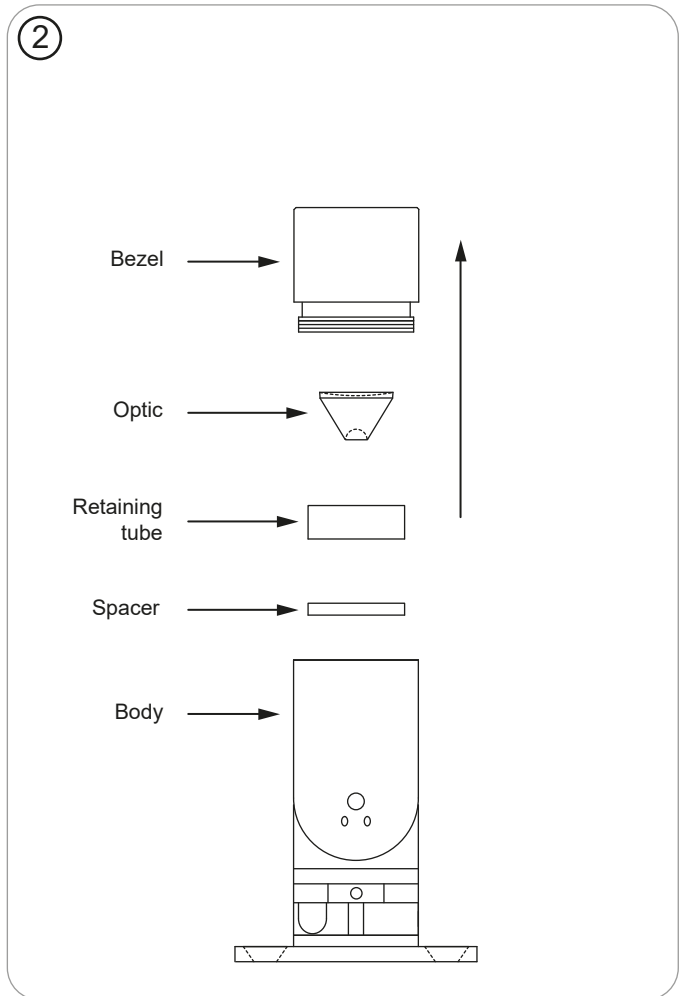
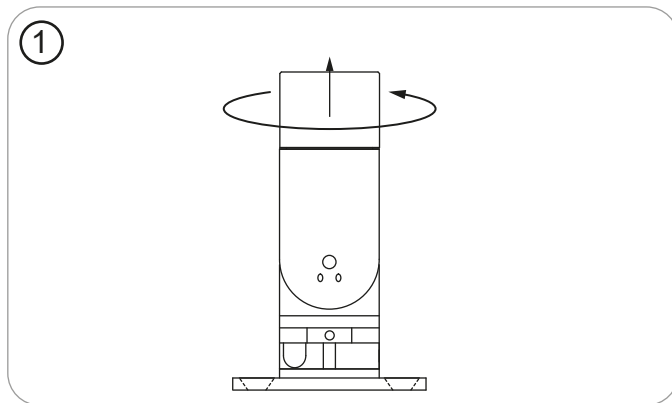

## Series Wiring

### SUPPLY

Installation must be carried out by a qualified electrician in accordance with BS 7671:2018 + A2:2022 Wiring Regulations. 230/240V AC 50/60Hz mains supply.

Mains cables must be double insulated and strain relieved.

Observe polarity:  
Positive (+) is marked as RED.  
Incorrect supply or reverse polarity can cause irreparable damage.

All connections must be made before switching on mains.

Ensure supply driver and connectors are housed indoors OR in a suitable IP rated enclosure.

Ensure LEDs are connected in 'series' as shown below to the LED drivers.

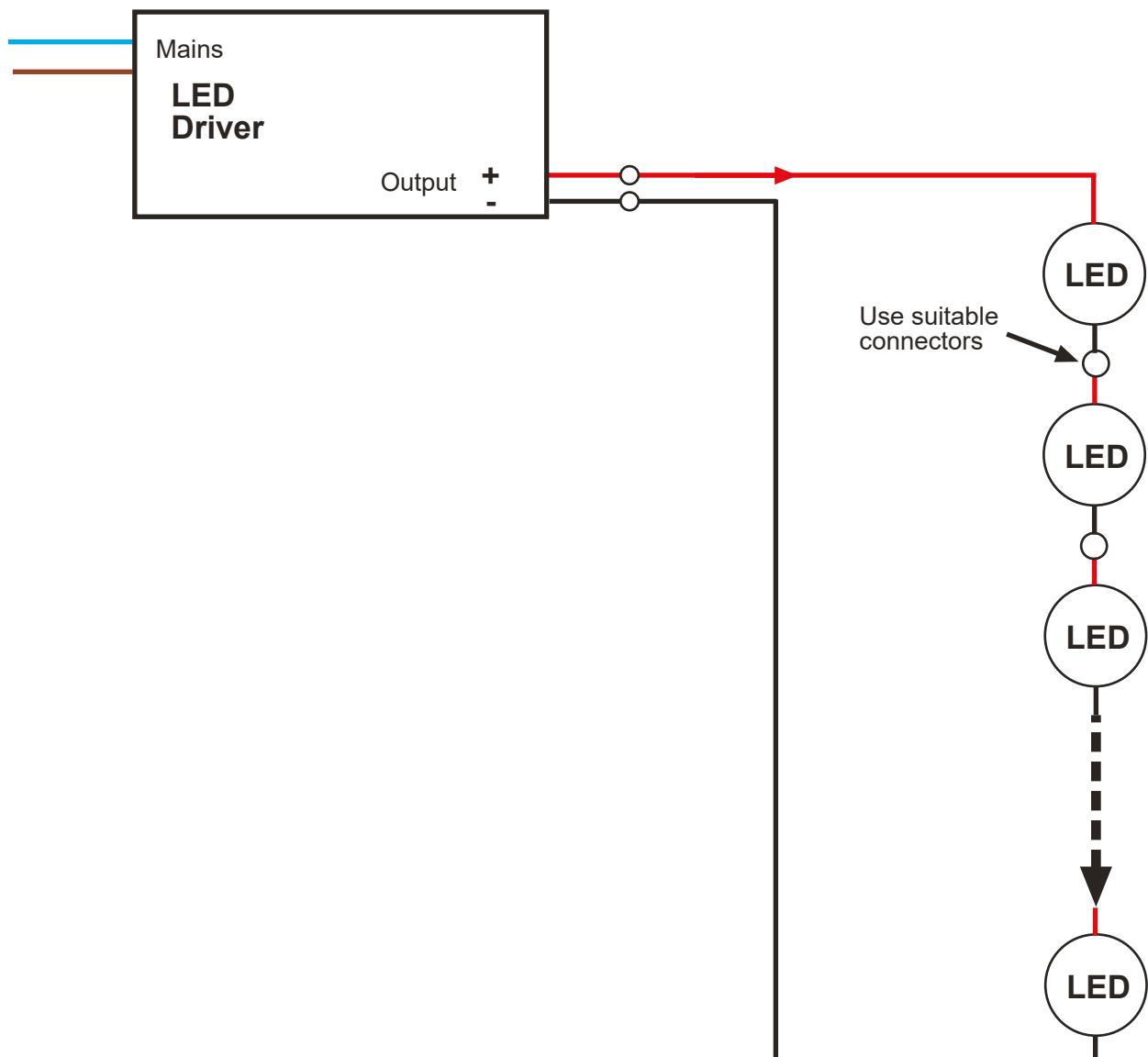

**STOANE LIGHTING**

EQUIPMENT DESIGN + MANUFACTURE

**Certified****Corporation**

Stoane Lighting firmly believe that we have a responsibility as environmental custodians, we believe that lighting equipment should be built to last, to be repaired and to be reused. As a BCorp we have pledged to operate a business not aiming to just be best *in* the world but a business best *for* the world. Stoane Lighting believe that the circular economy is a fundamental aspect of how we approach the challenges we face. If you read this at the end of the product life we encourage you to consider how you can ensure this product sees an extended life. If removal is unavoidable, please see the disassembly note below.

All Stoane Lighting products are supplied with a 5 year warranty and a 25 year duty of care.

Stoane Lighting operate a ReNew division, which can take your existing fittings and refurbish or upgrade without the need for replacing what you already have.



Through the ReNew service, Stoane Lighting provides general repair, deep cleans and electrical safety checks on luminaires, as well as possible repainting if needed. We will replace components that are nearing end of life, such as drivers, LEDs, and optics. If the fittings are to be used in a new area, or the existing space is undergoing a change in use, ReNew can offer a different mounting method or light technical performance (such as colour tuning), if needed, alongside the addition of on-board wireless control. ReNew as a service, depending on location, can be done on site or by returning equipment to Stoane Lighting.



Once fittings have been repaired or upgraded through ReNew, they will start a new five-year warranty period, and any unwanted parts will be recycled.



Product Disassembly and Component Recycling - While every effort has been made to ensure that our products are built to last and are ReNewable, there may come a point when, as a very last resort, the fittings need to be recycled. The Stoane Lighting website will provide information on how the fitting can easily be disassembled into its component parts for more effective recycling. Information on recycling services in your local region can also be supplied on request.

For more information on the above please visit [stoanelighting.com](http://stoanelighting.com) or contact us at the address shown.