



All of our in-house printed paper is 100% recycled and recyclable

STOANE LIGHTING

EQUIPMENT DESIGN + MANUFACTURE



Indehandrail Module

Installation and Maintenance Instructions

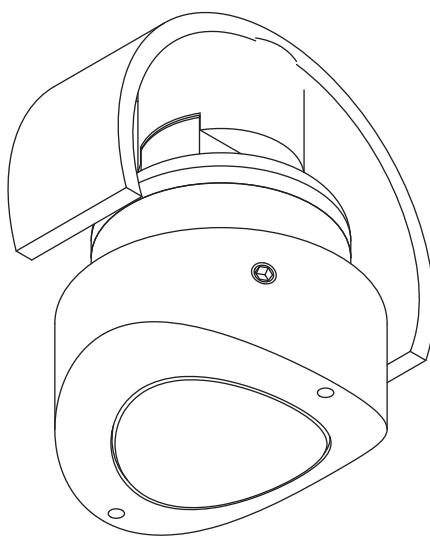

IMPORTANT: All wiring connections must be made before switching on mains power.



SL Star 2.9V_F 2W @ 700mA



This product should not be disposed of in your general waste



Please retain these instructions for future reference



Class III - Extra Low Voltage

IP66 Dust tight and protected against powerful jets of water.



European Conformity

Stoane Lighting Ltd
20 Dryden Road Bilston Glen Ind Est.
Loanhead Midlothian EH20 9LZ UK

T: +44 (0) 131 440 1313
F: +44 (0) 131 440 0049
sales@mikestoanelighting.com

www.stoanelighting.com
VAT No GB682885284
Limited Company 188910

Electrical Supply

Installation must be carried out by a qualified electrician in accordance with BS 7671:2008 Wiring Regulations. 230/240V AC 50/60Hz mains supply to a suitable SELV LED Driver.

Site conditions: LED equipment is more susceptible to static damage and over voltage than previous technology. Before handling or connecting to the mains supply ensure that all Stoane Lighting (SL) products are protected from static discharge and that the mains supply is to regulation. (230V +10 -6%)

Mains cables must be double insulated, strain relieved and separated from E.L.V output cables.

This unit requires a constant current driver. 700mA Max.

Observe polarity:

Positive (+) is marked as RED.

Incorrect supply or reverse polarity can cause irreparable damage.

All connections must be made before switching on mains. If the supply is energised prior to making the connections to the fitting then the resulting surge will damage the LED.

Multiple LEDs should be wired in series, refer to driver instructions for minimum/maximum load.

The entire dimming control circuit source must be of SELV insulation class.

Maintenance:

All lighting equipment is delicate and easily damaged through misuse or inappropriate installation (mechanical or electrical). Repairs and replacements may cause delays and will be chargeable. Contact SL for support if required.

All Stoane Lighting products are covered by a five year Warranty and a 25 year Duty of Care. Products are designed to be upgraded, adapted and refreshed using our comprehensive ReNew service. For more information on our ReNew service and for full Warranty terms and conditions visit stoanelighting.com or contact us at the address shown.

The light source contained in this luminaire shall only be replaced by the manufacturer or his service agent or a similar qualified person.

Caution - This product contains magnets. Magnets are dangerous if ingested, can affect pacemakers and other magnetically sensitive equipment.

Installation

Check that the mounting surface is suitable for the installation of this fitting.

A 33mm diameter hole is required for mounting.

Step 1 Insert the retaining circlip into the cut-out by rotating it into position. Position using the supplied tool.

Step 2 Make mains connections to SELV LED driver and extra low voltage connections to the fitting through the cut-out.

Step 3 Fit module into handrail. The fitting should be placed into the matching slot on the the retaining clip where the magnet will hold it in place.

Ensure supply driver and connectors are housed indoors OR in a suitably IP rated enclosure. Cable ends must be suitably waterproofed. Inspect supply cables before installation to ensure there is no damage which will allow water to enter the fitting.

After opening the sealed portion of the luminaire for any reason, SL recommends running the fitting for 15 minutes with the lid open to expel moisture before closing it up. This will prevent condensation on the lens and protect the fitting from corrosion.

Care must be taken when handling any ingress protection seals, glands or "O" rings to ensure they are kept clean, unblemished and replaced exactly in their required location and suitably fastened home.

The IP rating stated is applicable only when the fitting has been installed as per these instructions.

WARNING: Do not look at exposed LED lamps in operation. Eye injury can result.

Cleaning:

Fully isolate the fitting and allow to cool.

Clean the fitting with a slightly damp lint free cloth from a mild solution of soap and water. The fitting must be completely dry before reconnecting power.

Incompatible or abrasive chemicals can damage the fitting, contact SL for advice if required.

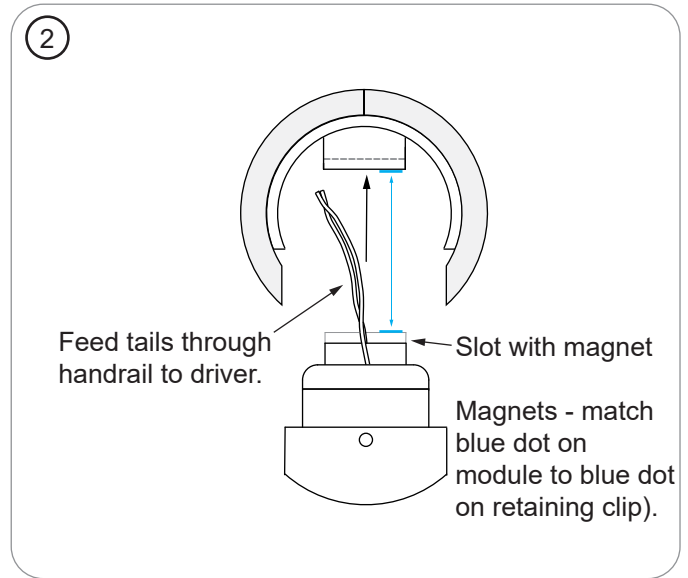
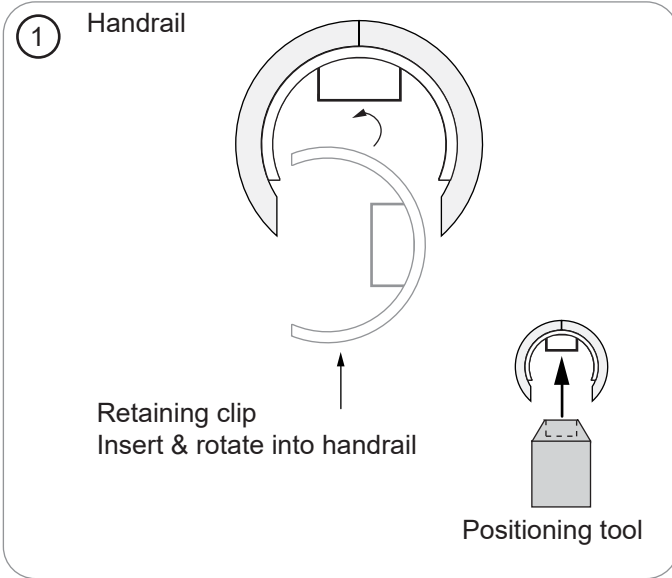

To Remove Fitting

The fitting can be removed from the handrail via the two M2 threads on the front of the bezel. Screw two M2 fixings into the threads and use them to pull the fitting out of the handrail.

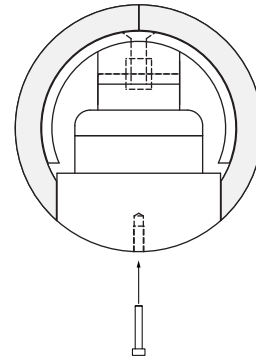

Certified

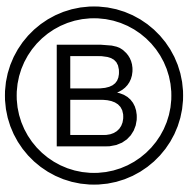

Corporation

Stoane Lighting firmly believe that we have a responsibility as environmental custodians, we believe that lighting equipment should be built to last, to be repaired and to be reused. As a BCorp we have pledged to operate a business not aiming to just be best *in* the world but a business best *for* the world. Stoane Lighting believe that the circular economy is a fundamental aspect of how we approach the challenges we face. If you read this at the end of the product life we encourage you to consider how you can ensure this product sees an extended life. If removal is unavoidable, please see the disassembly note below.

All Stoane Lighting products are supplied with a 5 year warranty and a 25 year duty of care.

Stoane Lighting operate a ReNew division, which can take your existing fittings and refurbish or upgrade without the need for replacing what you already have.



Through the ReNew service, Stoane Lighting provides general repair, deep cleans and electrical safety checks on luminaires, as well as possible repainting if needed. We will replace components that are nearing end of life, such as drivers, LEDs, and optics. If the fittings are to be used in a new area, or the existing space is undergoing a change in use, ReNew can offer a different mounting method or light technical performance (such as colour tuning), if needed, alongside the addition of on-board wireless control. ReNew as a service, depending on location, can be done on site or by returning equipment to Stoane Lighting.



Once fittings have been repaired or upgraded through ReNew, they will start a new five-year warranty period, and any unwanted parts will be recycled.



Product Disassembly and Component Recycling - While every effort has been made to ensure that our products are built to last and are ReNewable, there may come a point when, as a very last resort, the fittings need to be recycled. Stoane Lighting can provide information on how the fitting can easily be disassembled into its component parts for more effective recycling. Information on recycling services in your local region can also be supplied on request.

For more information on the above please visit stoanelighting.com or contact us at the address shown.