

G3.2 Exterior LED Channel

Installation and Maintenance Instructions

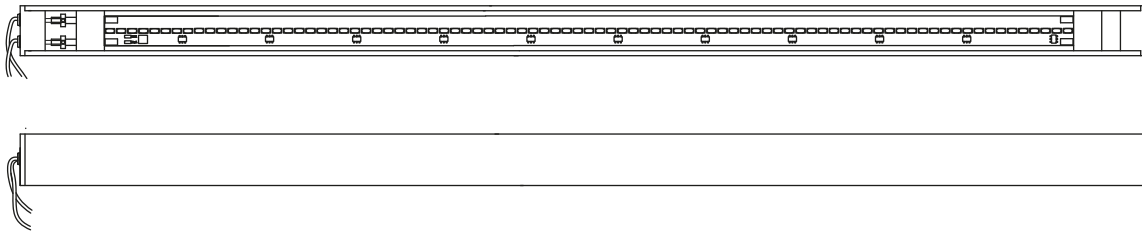

IMPORTANT: All wiring connections must be made before switching on mains power.

IP66 Dust tight and protected against powerful jets of water.

Please retain these instructions for future reference

This product should not be disposed of in your general waste

G3.2 LED Strip Standard Output

Power	16.8 w per metre
Output	1496 lm per metre

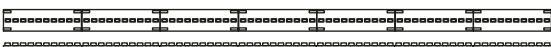

Class III - Extra low voltage

European Conformity

Suitable for Exterior use

G3.2 LED Strip High Output

Power	31.2 w per metre
Output	2702 lm per metre

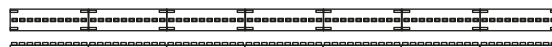

Electrical Supply

Installation must be carried out by a qualified electrician in accordance with BS 7671:2008 Wiring Regulations. 230/240V AC 50/60Hz mains supply to a suitable 24V SELV PSU.

Site conditions: LED equipment is more susceptible to static damage and overvoltage than previous technology. Before handling or connecting to the mains supply ensure that all MSL products are protected from static discharge and that the mains supply is to regulation. (230V +10 -6%)

Mains cables must be double insulated, strain relieved and separated from E.L.V output cables.

This luminaire requires a 24V constant voltage PSU.

Observe polarity:
Positive (+) is marked as RED.
Incorrect supply or reverse polarity can cause irreparable damage.

All connections must be made before switching on mains.
If the supply is energised prior to making the connections to the fitting then the resulting surge will damage the LED.

Multiple LEDs should be wired in parallel, refer to driver instructions for minimum/maximum load.

All lighting equipment is delicate and easily damaged through misuse or inappropriate installation (mechanical or electrical). Repairs and replacements may cause delays and will be chargeable. Contact MSL for support if required. For full warranty terms & conditions please visit our website.

The IP rating stated is applicable only when the fitting has been installed as per these instructions.

The light source of this luminaire is not replaceable; when the light source reaches its end of life the whole luminaire shall be replaced.

Dimming control circuit source must be of SELV insulation class.

Ensure supply driver and connectors are housed indoors OR in a suitably IP rated enclosure. Cable ends must be suitably waterproofed. Inspect supply cables before installation to ensure there is no damage which will allow water to enter the fitting.

Installation

Check that the mounting surface is flat and suitable for the installation of this fitting.

Step 1 Attach LED channel to the mounting surface using the mounting tabs if supplied. Mounting tabs should be spaced evenly along the channel using approximately two per metre.

Step 2 Connect mains supply to the PSU, connect dimmer (If required) and make E.L.V connections to the fitting wired in parallel.

WARNING: Do not look at exposed LED lamps in operation. Eye injury can result.

Cleaning:

Fully isolate the fitting and allow to cool.

Clean the fitting with a slightly damp lint free cloth from a mild solution of soap and water. The fitting must be completely dry before reconnecting power.

Incompatible or abrasive chemicals can damage the fitting, contact MSL for advice if required.

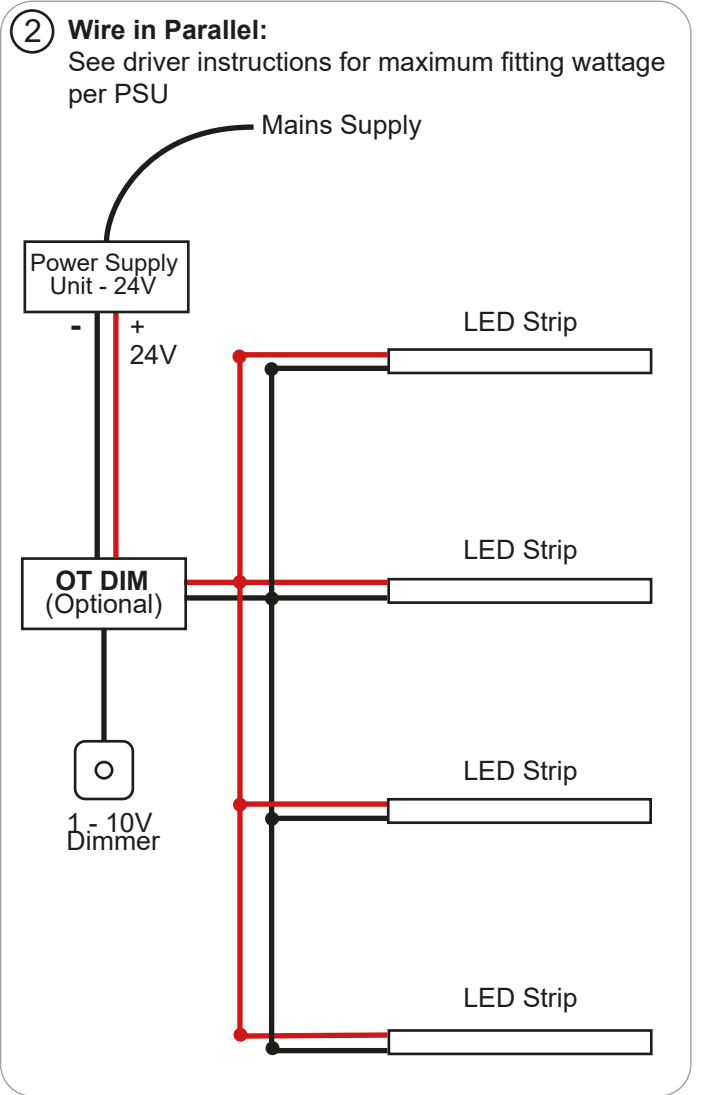
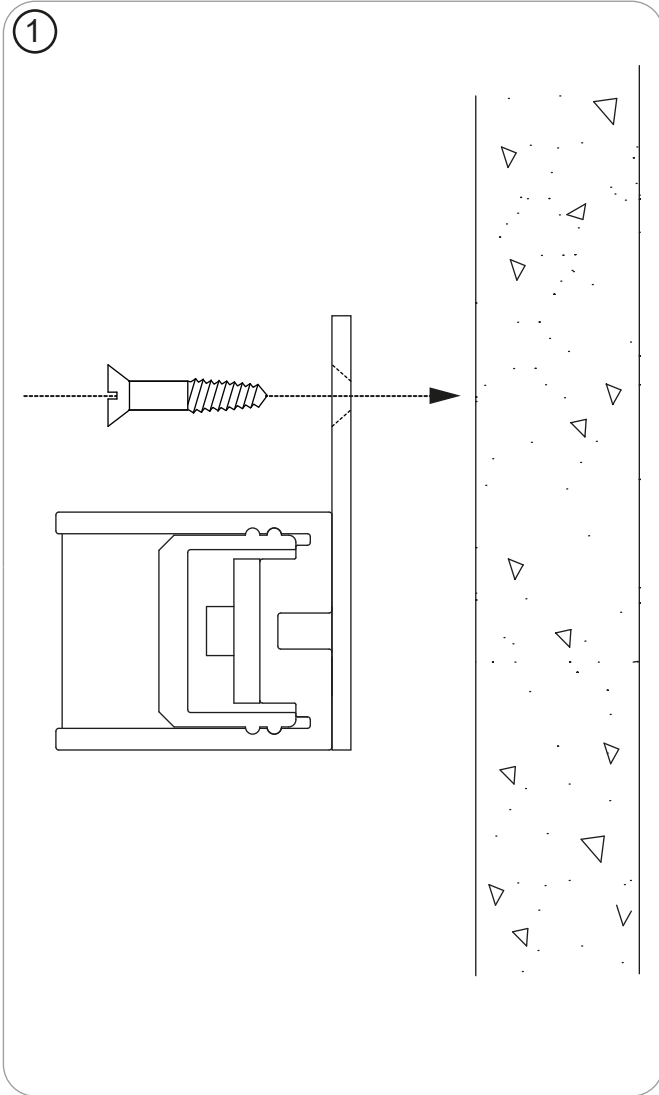

MOUNTING TAB ADJUSTMENT

The mounting tabs position can be adjusted by removing the supplied fixing on the back of the LED channel.

Once removed the tab can be rotated and moved to suit installation.

After adjustment, screw the tabs back on using the threaded slot in the back of the channel.

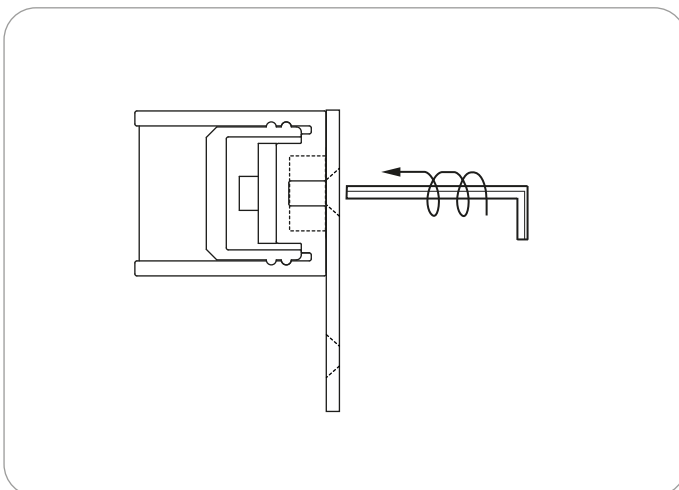
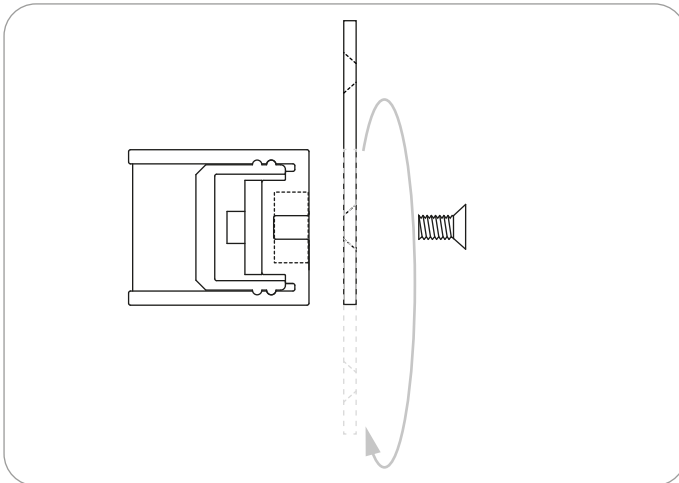
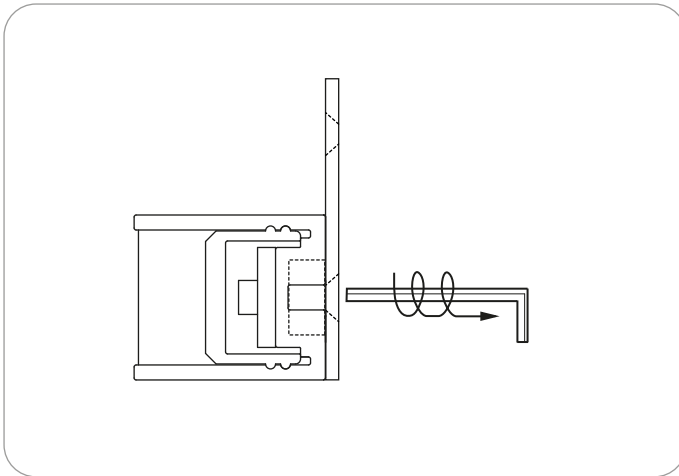

DO NOT OVER TIGHTEN TAB SCREWS

Use the Allen key as shown to be
finger tight only

Over tightening the screws could
result in irreparable damage.

